

3000-0001-HNG L

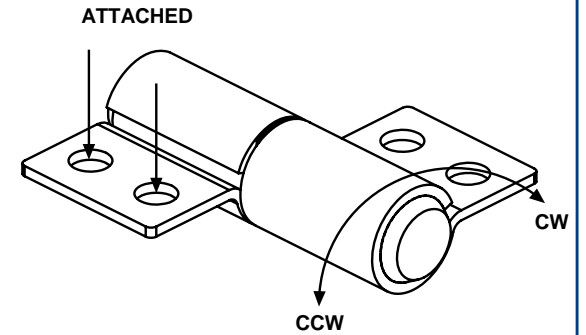

3000-0001-HNG R

TORQUE SPECIFICATIONS		
PART NUMBER	CW	CCW
3000-0001-HNG L		
3000-0001-HNG R		

HANAYA		INTERFACE DRAWING		
<small>ALL INFORMATION ON THIS PRINT ARE PROPRIETARY TO HANAYA, AND SHALL NOT BE USED IN WHOLE OR IN PART WITHOUT HANAYA'S CONSENT.</small>		ENGLISH [METRIC]		MATERIAL
		TOLERANCES		STEEL BAND & SHAFT
SUITABLE MOUNTING SCREWS		METRIC	ENGLISH	SIZE DWG NO.
FRACTIONAL	8-32 UNC	.X ±.3 MM	.XX ±.015 IN	3000-0001-HNG L & R
METRIC	M4 X 0.7	.XX ±.13 MM	.XXX ±.005 IN	
		.XXX ±.005 MM	.XXXX ±.002 IN	
		ANGLE ± 1°		